ABSTRACT

This paper will compare properties of Sliding Mode Controlled (SMC) and classical Proportional Integral (PI) controlled brushless DC motor (BLDC) in applications. It is the simple strategy required to achieve good performance in speed or position control applications. This paper addresses controlling of speed of a BLDC motor which remains among the vital issues. A BLDC motor is generally controlled by Proportional plus Integral (PI) controller. PI controller is simple but sensitive to parameter variations and external disturbance. Due to this reasons, Sliding Mode Control (SMC) is proposed in this paper. This control technique works against parameters variations and external disturbances, and also its ability in controlling linear and nonlinear systems. Performance of these controllers has been verified through simulation using MATLAB/SIMULINK software. The simulation results showed that SMC was a superior controller than PI controller for speed control of a BLDC motor

KEYWORDS: BLDC Motor ,Speed Control, Proportional plus Integral Controller, Sliding Mode Control

INTRODUCTION

Brushless DC motors[1,2] have been used in various industrial and domestic applications because of its overweighing advantages like simple structure, large torque, don't need to change phase based on the brush, and has long use time, good speed regulation. In earlier days the controlling system of BLDC motor adopted hall sensor signals to drive the motor. But when disturbance on the hall sensor exists, the misbehavior of the main circuit prompts the BLDCM action unsteady, the reliability of the whole controlling system is greatly reduced, also the cost of controller is increased. In recent years, some of these developments like Proportional- Integral (PI) [3] controllers have been implemented for the speed control of BLDC motors. BLDC motors can be controlled by used various advanced control theories like the optimal [4] and adaptive [4] strategies. Neural network control [4] has also been used to control these motors but its performance under load disturbances and parameter uncertainty due to the non linearity cannot give expected results.

Sliding mode control [5,6] is a technique that originated in Soviet literature, in the early 1950's initiated by S. V. Emel yanov, with advantages like order reduction, disturbance rejection and invariance to parametric variations have now become very popular for designing of robust system performance. Speed and current control of different motor drives [4,7,8] is amongst many of its other areas of application.

BLDC MOTOR AND ITS MODEL

BLDC motor is widely used because of its advantages like high efficiency, high power density, torque, fast response and low inertia. Fast dynamic response, higher steady precision, and stronger antiinterference capability is required in many applications for the motor speed regulation system. These motor also has better speed vs. torque characteristics, High dynamic response, long operating life, Noiseless operation, high speed ranges and Low maintenance.

The permanent magnet brushless motor has a permanent magnet rotor, and the stator windings are wound such that the back emf is trapezoidal. It requires rectangular shaped stator phase currents to produce constant torque. The trapezoidal back emf implies that the mutual inductance between the stator and rotor is non-sinusoidal. The parameters of the 3-phase motor model used in this paper are illustrated in Table 1

Table IV: BLDC Motor Specification

PARAMETER	Symbol	Value
Phase Resistance	R	0.18(ohm)
Phase Inductances	L	0.835(Mh)
Back EMF constant	Ke	3.86(V/rad/s)
Torque constant	Kt	36.8
Pole pairs	P	4
Rotor Inertia	Jm	.0006(kgm^2)
Peak Torque	T	154(mNm)
Rated Voltage	Vdc	72(volt)

The mathematical model of the motor is developed based on the following assumptions.

- The motor is star connected.
- Iron losses and mechanical losses of the motor were neglected.
- The motor is not saturated.
- Stator resistances of all the windings are equal and self and mutual inductances are constant.

The model of BLDC motor is similar to that of a DC motor. Only here the presence of an electronic commutator causes the state trajectory to switch between different models. Here the model of a BLDC similar to that of a DC motor is developed. By incorporating the presence of an electronic commutator the developed model can be used as a BLDC drive model.

The differential equation governing the electrical part of the model can be written as

$$V = IR + L \frac{di}{dt} + E \quad (1)$$

Where, V = DC voltage applied in Volts.

L = Inductance of the windings in Henry.

R = Resistance of the windings in Ohms.

E = Back Emf of the motor.

Kb = Back Emf constant in Volts/ rad/sec.

W = Speed in rad/sec.

Above the equation (1) can also be written as

$$\frac{di}{dt} = \frac{1}{L} (-E - IR + V) \quad (2)$$

Where, i = Current in Ampere.

V = Voltage as input.

E = Disturbance input.

The mechanical part of the model can be obtained by the following differential equation as,

$$T = \frac{dw}{dt} + Bw + TL \quad (3)$$

Where,

T = Torque in Newton-meter

J = Moment of inertia

TL = Disturbance input.

The above equation in (3) can also be written as

$$\frac{dw}{dt} = \frac{1}{J}(-Bw + T + TL) \quad (4)$$

CONTROL TECHNIQUES OF BLDC MOTOR

There are several approaches in variable speed drive control of BLDC motors such as PI, FUZZY, neural network, genetic programming and hybrid algorithms. In this paper we make comparison between PI and SMC control of BLDC drives.

(a) PI controller:

The proportional integral controller is about the most common and useful algorithm in control system engineering. The feedback loops are controlled using PI algorithm. Feedback is very important in systems in order to attain a set point irrespective of disturbances or any variation in characteristics of any form. PI controller is designed to correct error between the measured process value and a particular desired set point in a system.

The Proportional (P) and Integral (I) controls the system S, using the controller C where the controller efficiency depends on P and I parameters.

- A PI speed controller has been chosen with gain parameters Kp and Ki.
- The speed of the motor compared with the reference value and the error in speed is processed by the speed controller.
- The output of the PI controller at any instant is the reference torque given by

$$T_{ref} = \{K_p + K_i/s\} \{W_{ref} - W_r\} \quad (5)$$

Where Tref is the reference torque Kp is the proportional gain of the PI controller. Ki is the integral gain of the PI controller. Wref is the reference speed in rad/sec. Wr is the actual speed in rad/sec.

Fig.1 presents a block diagram for the control scheme of current implemented by PI controller with a saturation module. The actual value of current or speed is sensed from the output and sent to proportional and integral terms which contains the proportional term with gain and integral term with gain. The outputs are summed using a Sum block and the output is sent to saturation block for saturation purpose and output from this block gives the error between the reference value and actual value of the motor.

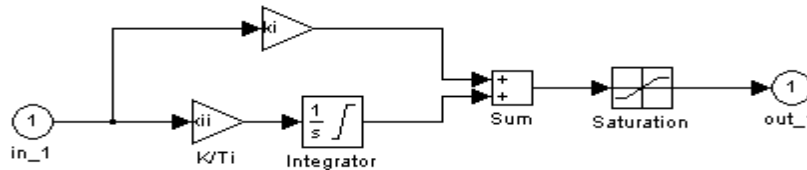

Fig 1 Block Diagram of PI controller

In PI controlled PMBLDC motor starting speed is greater than reference speed while in no load and on load condition. The time taken for speed to settle at reference speed after load is applied is less. Speed drop is less when load is applied. The time taken for torque to settle at reference torque after load is applied is low.

PI controllers have a simple control structure, inexpensive cost. However, when the system is nonlinear and when bounded uncertainties present in the system, PI controllers are not perfectly able to stabilize the system, particularly, when the nonlinearity is very high or the bound of uncertainty is large. In many practical problems, almost perfect disturbance rejection or control performance is required. It is also sensitive to parameter variations and external load torque.

(b) Sliding Mode Control:

In this control technique the concept of reaching law algorithm, emphasizing on the benefits of exponential reaching law are used to control the inner current loop and outer speed loop of the BLDC motor.

Sliding mode control is a typical non linear control technique, that modifies the system performance by continuous switching of the controlled variable according to the current status of the known system state and thereby causes the trajectory to move on a predefined sliding surface.

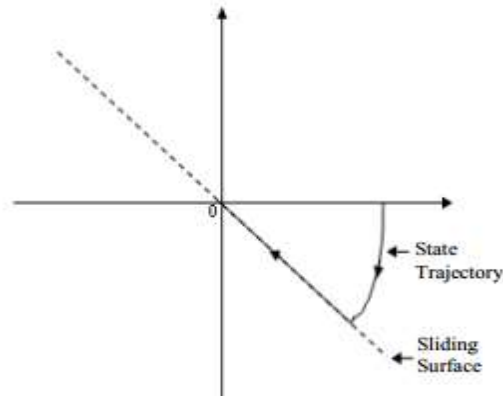

Fig 2 Phase Portrait of a sliding motion

Fig 2 represents the phase trajectory of a sliding mode representing two modes of the system. In the first part, the trajectory starting from anywhere on the phase plane moves towards the sliding surface and reaches the surface in finite time. This is known as reaching, hitting, or non-sliding phase and the system is sensitive to parameter variations and disturbance rejection in this part of the phase trajectory. The second part is the sliding phase in which the state trajectory moves to the origin along the sliding surface and the state never leave the sliding surface. During this period, the system is defined by the equation of the sliding surface and thus it is independent of the system parameters and external disturbances. Thus sliding mode design involves two major tasks:

- The selection of a stable sliding surface in state space on which the state trajectory must ultimately lie in.
- Designing a suitable control law that makes this sliding surface attractive for the state trajectory to reach it in finite time.

Sliding surface can be either linear or nonlinear. For simplicity, only a linear sliding surface is used in this paper. If the origin of the coordinate axes is taken as the stable equilibrium then the ultimate objective is to force the trajectory onto the sliding surface, “S” and then it should move towards the origin.

Slotine proposed a form of general equation to determine the sliding surface which ensures the convergence of a variable towards its desired value as:

$$S = \left(\frac{d}{dt} + \alpha \right)^{n-1} e \quad (6)$$

Where n is the system order, e is the tracking error signal, and α is a positive constant that determine the bandwidth of the system. Having chosen the sliding surface at this stage, the next step would be to choose the control law (u) that will allow the error to reach the sliding surface. To do so, the control law should be designed in such a way that the following condition, also named reaching condition, is met:

$$S \dot{S} < 0 \quad (7)$$

In order to satisfy this condition, exponential reaching law technique is adopted. The general representation of the exponential reaching law approach is given as

$$\dot{S} = -\varepsilon \operatorname{sgn}(s) - Ks \quad (8)$$

Where K, are positive constants known as the hitting control gain or parameter, s is the sliding surface, and sign is the signum function defined

$$\operatorname{sign}(s) = \begin{cases} 1 \\ -1 \end{cases} \quad (9)$$

The discontinuous control law described by Equations presents high robustness, insensitive to parameter fluctuations and disturbances. However, using a sign function often causes chattering phenomenon in practice.

Control Algorithm:

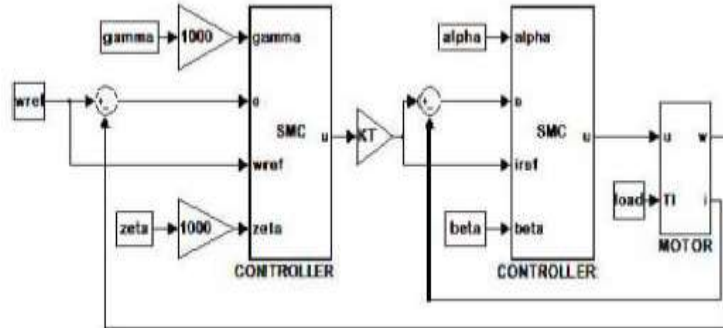

Figure.3. Block Diagram of BLDC Motor with Sliding Mode Controller.

The block diagram of the sliding mode controller is shown in Fig 3 which represents two controllers. In those two, one controller is used for current loop and other is used for speed loop of the BLDC motor. In the outer loop, the speed error of the motor is minimized by continuous varying of positive constants gamma (γ) and zeta (ζ), thereby reaching the desired speed of the motor.

The output from the speed controller is fed as input to the other controller which is designed for current control. In the inner loop, the current error of the motor is minimized by continuous varying of positive constants alpha (α) and beta (β), thereby causing the motor to run at required current.

By employing the exponential reaching law approach the sliding mode controllers can be designed. For inner current loop, the sliding mode controller, S1 can be obtained as

$$V = L \left[\alpha \operatorname{sgn}(s1) + \beta s1 + \frac{di}{dt} \right] + E + (i - e1)R \quad (10)$$

Where, α, β are constants, e1 is the current error signal; S1 is the smc controller for current loop. Similarly for outer speed loop, the sliding mode controller, S2 obtained is

$$T = J \left[\gamma \operatorname{sgn}(s2) + \zeta S2 + \frac{dw}{dt} \right] + TL + (w - e2)B \quad (11)$$

Where, γ, ζ are constants, e2 is the speed error signal S2 is the smc controller for speed loop.

RESULTS AND DISCUSSION

The motor is started at no-load and reference speed is set at 100 rad/sec at no load . Load torque of 1 Nm is applied after 1 sec. The motor is rated at 100 V, 2 Nm and 100 rad/sec. The results of PMBLDC motor with PI and SM controllers are compared. The variation of current, torque and speed are shown in Fig. 4, Fig.5 and Fig. 6.

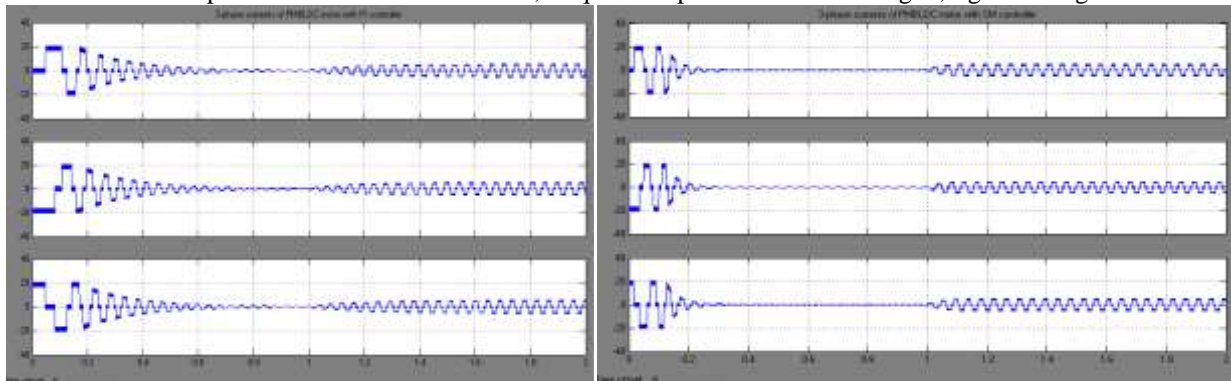

Fig. 4. Three Phase current waveforms of PMBLDC motor for a step change in load of 1Nm at t=1 sec for (a) PI controller (b) SM controller.

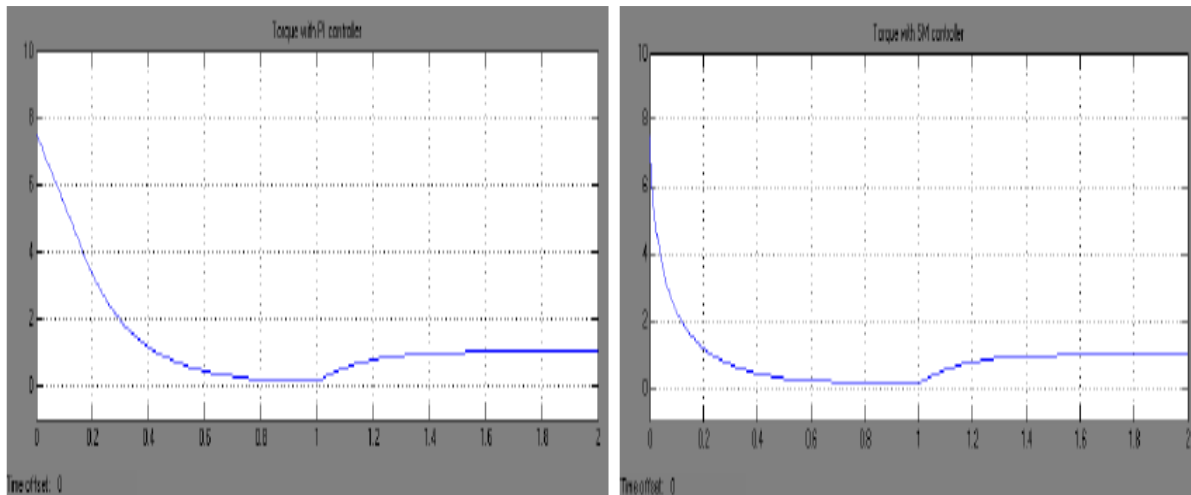

Fig. 5. Torque response of PMBLDC motor for a step change in load of 1Nm at $t=1$ sec for (a) PI controller (b) SM controller.

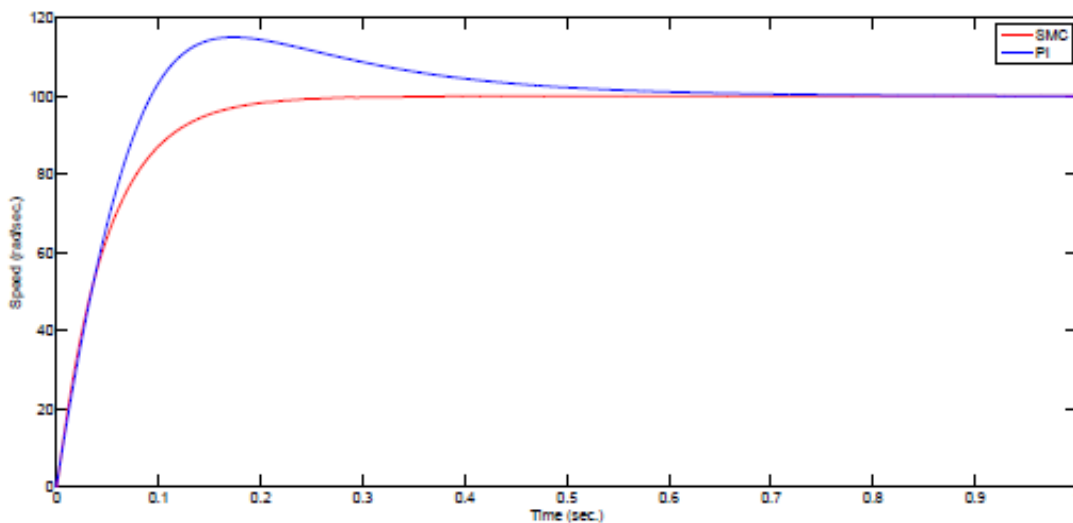

Fig 6. Speed of BLDC Motor with SMC and PI Controller

The current waveforms are shown in the Fig. 4 (a) and Fig. 4 (b) respectively. The initial peak current is 20 A for both the controllers. In PI controller, the initial current oscillations are more and subsided after 0.9 sec. But in SM controller the oscillations are less and subsided after 0.45 sec only. After load is applied the rms value of current with PI controller is 3.8 A and with SM controller is 3.5 A. Also there is a low frequency oscillations of current during starting with SM controller.

The torque waveforms are shown in the Fig. 5 (a) and Fig. 5 (b). The torque at starting is 7.5 Nm with PI controller and 6.5 Nm with SM controller. Also the torque response is faster in the latter case. The steady-state torque of 1 Nm is reached in 0.6 sec with PI controller and with SM controller is 0.4 sec.

The speeds of the motor with SMC and PI controller are shown in fig.6. Simulation results show that the SMC realized a good dynamic behavior of the motor with a rapid rise time and settling time, and had better performance than the PI controller related to reduction in steady state error, faster settling time, smaller overshoot in the speed response and much better disturbance rejection capabilities against parameter variations and external load torque.

Table 9. Simulation Results with SMC and PI Controller

Parameter	Symbol	PID	SMC
Speed(Error)	ew	0.064%	0.024%
Current(Error)	ec	0.029%	0.14%
Speed Settling Time(sec)	tc	0.52	0.195
Current Settling Time(sec)	tw	0.6	0.185
%Overshoot(speed)	Mp	15	0

CONCLUSION

This paper is intended to compare the two Controllers namely, Proportional-Integral (PI) controller and sliding mode controller (SMC) for the speed control of a permanent magnet brushless DC motor. It is observed that SMC provides important advantages over the traditional PI controller like limiting the overshoot in speed, thus the starting current overshoot can be reduced. From the simulation results, both techniques give almost identical result. However, simulation result show that the sliding mode controller realized a good dynamic behavior of the motor with a rapid rise time and settling time, and had better performance than the PI controller related to reduction in steady state error, faster settling time, smaller overshoot in the speed response and much better disturbance rejection capabilities against parameter variations and external load torque.

REFERENCES

- [1] Reimers, Eberhart, "An application of two phase DC chopper drive ".Industry Applications ", IEEE transactions on May 1973.
- [2] S.B.Ozturk and H.A.Toliat, "Direct Torque Control of Brushless DC Motor with Nonsinusoidal Back-EMF", Electric Machines and Drives Conference, 2007.
- [3] Tan Chee Siong, Baharuddin Ismail, Mohd Fayzul Mohammed, Mohd Faridun Nairn Tajuddin, Siti Rafidah Abdul Rahim, Zainuddin Mat Isa, "Study of Fuzzy and PI controller for Permanent-Magnet Brushless DC motor drive ".Power Engineering and Optimization conference, 2010.
- [4] Yan Xiaojuan, Liu Jinglin, "A Novel Sliding Mode Control for BLDC Network Control System ", 3rd International Conference on Advanced Computer Theory and Engineering, 2010.
- [5] Weibing GAO, "Variable Structure Control of Non-linear Systems: A New Approach", IEEE transactions on Industrial Electronics, VOL 40.No.I, February 1993.
- [6] John Y Hung, Weibing GAO and James C.Hung, "Variable Structure Control: A Survey" in IEEE transactions on Industrial Electronics, VOL 40.No.I, February 1993.
- [7] Zhiyuan, Xiaoxian Yao and Zheng Liu, " Slide Mode Variable Structure Control for BLDC Electric Actuator", in Proceedings of 7th World Congress on Intelligent Control and Automation, 2008, China.